

Tension and Compression Load Cell

Model 8524

1. Introduction

The load cells in the model 8524 series are primarily designed for the measurement of force in production equipment, using Newtons (N) as the unit of measurement.

The local gravitational acceleration ($g \approx 9.81 \text{ m/s}^2$) must be taken into account when determining masses.

2. Preparations for use

2.1 Unpacking

- Inspect the sensor carefully for damage.

If you suspect that the unit has been damaged during shipping, notify the delivery company within 72 hours. Keep all packaging materials for inspection by the representative of the manufacturer or delivery company.

- Only transport the model 8524 sensors in their original packaging or in packaging of equivalent quality.

2.2 Using the instrument for the first time

- Only connect the sensor to instrumentation amplifiers that are fitted with a safety transformer according to EN 61558.

Note:

Transmitters connected to the outputs or other devices that are galvanically connected to the sensor's signal lines must also be fitted with safety transformers according to EN 61558.

2.3 Grounding and potential connection

All connecting wires (including the cable screening braid) are electrically insulated from the sensor body.

The insulation resistance between the connecting wires and the sensor body is measured.

The test certificate states that the minimum resistance is greater than $30 \text{ M}\Omega$ (test voltage 45 V).

2.4 Storage

- The sensor must be stored under the following conditions only:
 - dry
 - no condensation
 - temperature between 0 °C and 60 °C

Note:

Provided the storage conditions have been observed, no special steps need to be taken after storage and prior to commissioning.

3. Principle of operation

The sensor operates with the aid of a spring element. The force to be measured deforms the spring element elastically.

This deformation is transformed into an electrical signal by strain gauges. They, together with the spring element, constitute the measuring element of the sensor.

3.1 Spring element

The spring element is the most important mechanical part of a load cell. Its purpose is to take the force being measured and convert it into a linear extension. It relies on the elastic properties of the material in order to determine the force indirectly.

The materials of which load cells are made must satisfy other conditions in addition to their elastic properties. As a result, only a small number of carefully selected materials come into question for high-quality load cells.

burster is going one step further than this, using mainly materials from the aeronautical industry that satisfy additional quality requirements in the place of DIN materials.

3.2 Mechanical design

In the 8524 devices, a horizontally-mounted elastic membrane with central ring for load insertion is used as the spring element.

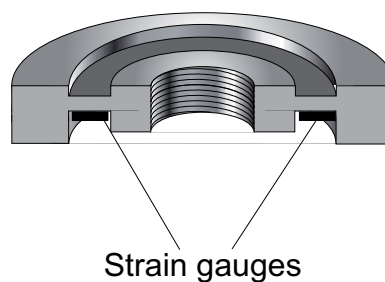

Figure 1: horizontally mounted membrane

This elastic membrane is deflected by the applied force, resulting in a reduction in the sensor's overall height. This deformation cannot be seen by the naked eye. It is measured by strain gauges. In the 8524 devices, the strain gauges are mounted on the underside of the spring element. This ensures that they are subject to the same deformation as the spring element.

3.3 Function of the strain gauge

The electrical resistance of a wire rises with increasing length and falling cross-section. When a wire is pulled, it becomes thinner and longer – both of these effects result in an increase in its electrical resistance.

This is the principle on which the function of strain gauges is based. In practice, however, strain gauges do not consist of a single wire, but of a metal foil laminated onto a carrier material. The metal foil is etched to create a meandering structure (see. Figure 2:).

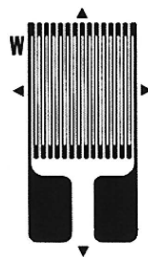

Figure 2: Foil strain gauge

Special techniques are used to mount strain gauges manufactured in this way onto the surface of the spring element.

3.4 Strain gauge wiring

In order to reduce undesirable influences on the measurement, the strain gauges in the model 8524 sensors are connected as a Wheatstone bridge. Figure 3 illustrates this wiring in a simplified form.

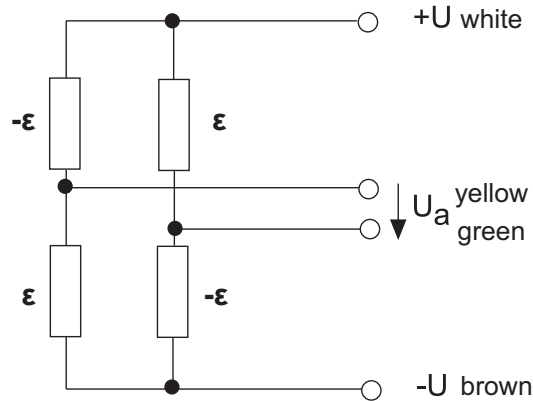

Figure 3: Full-bridge strain gauge

In addition to the four strain gauges shown here, compensation resistors to reduce the effect of temperature and balancing resistors to balance the bridge circuit are also incorporated.

Depending on the sensor model, further resistors for the purpose of standardizing the rated characteristic are integrated into the cable or the connector.

The output voltage of the sensor at maximum load, U_a , is calculated as follows:

$$U_a = c \times U_b$$

- U_b : excitation voltage
- c : characteristic value (sensitivity) of the sensor.

The sensitivity parameter "c" can be found in the test report. It is typically in the range of $1.5 \text{ mV} \pm 0.25 \%$.

If excitation voltages (U_b) in the range of maximum 10 V (we recommend 5 V) are used, 0...100 % loading of the sensor yields output voltages (U_a) in the range of 7.5 mV.

3.5 Deflection full scale

For sensors with diaphragm, the load lowers the middle of the measuring element. This deformation, known as the deflection full scale, is so small that it cannot be seen with the naked eye. For sensors of the model 8524 it is approx. 80 μm at max. load, dependent on the sensor's measurement range. The deflection is directly proportional to the load.

3.6 External forces



Caution.

Sensor will be damaged!

Avoid vibrations, even if the loads caused by these vibrations are less than the rated maximum. Design your measuring system in such a way as to prevent these external forces.

Note:

External forces, acting on the sensor, adulterate the result materially.

External forces here refer to any force that acts outside the sensor's axis of symmetry - transverse forces, bending moments and twisting moments in particular.

3.7 Overload protection

- Install an overload protection mechanism.

burster offers this sensor optionally with an mechanical overload protection for compressive forces up to measurement range 0 ... 20 kN (Option ...-V400).

- Provide pressure limiters for any hydraulic or pneumatic cylinders acting on the sensor.
- Absolutely avoid any load that applies a sudden force (pulse).

The high spring constant of the sensor results in high negative accelerations for moving objects. This generates extremely high forces.

If, despite precautions, the sensor has been overloaded, you will notice this immediately by a change in the output signal for the zero point.

- Get the sensor checked out if you notice a change in the signal of 5 % or more (higher or lower) while no load is present.

4. Installation

4.1 Surrounding mechanical parts and fastening

4.1.1 Adaptation

Mounting surface

A high quality measurement depends on a defined deformation of the measuring element under load. In order to be certain of excluding any unwanted deformations, the sensor must lie flat on the mounting surface.

The mounting surface must satisfy the following requirements:

- adequately stable
 - hardened, minimum hardness 60 HRC
 - polished, preferably lapped, surface quality: N3 (RZ1), evenness 2 μm
 - not coated in any material
 - must contain no holes or milled slots this also means centering holes
 - Flat
- Eliminate any transverse forces, bending moments and twisting moments.

Applying the force

- Apply the force to be measured through the central thread into the load cell
- Apply the force in the center.

This means that you must apply the force exactly along the axis of symmetry of the sensor. The force must act in a direction perpendicular to the sensor.

- Eliminate any lateral forces and torques.

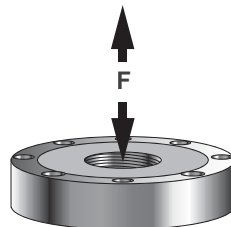

Figure 4: Applying the force to 8524

Note:

burster praezisionsmesstechnik offers pull plates (model 8590), for all measurement ranges of this sensor. These pull plates allow the application of forces on both sides, through the central thread

4.1.2 Mounting

The entire bearing area of the sensor must be mounted on a base which is hardened (60 HRC), flat, polished or better lapped.

Screws

Note:

You may find the maximum torques of the mounting screws in the actual data sheet.

- Only use screws that offer these features:
 - Mechanical strength of screws: 12.9 or better
 - head cap screws in compliance with DIN 912.
 - Counter bores in compliance with DIN 74-km

Measurement ranges up to 0 ... 2 kN:

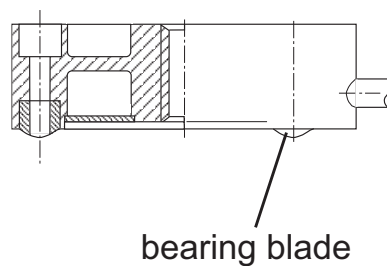

Figure 5: 3 clearance holes with edges for three-point-support

Measurement ranges from 0 ... 5 kN and above:

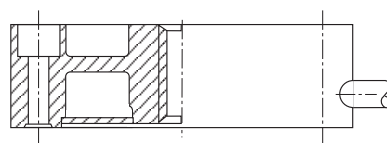

Figure 6: 6 resp. 8 clearance holes

4.2 Electrical system, evaluation instrumentation



Caution.

If the cable sheath is damaged, fluids can penetrate and damage the sensor.

For this reason:

Take suitable precautions to relieve the bending stress exerted by the connecting cable on the cable bushing at the sensor housing. In particular, pulsating or alternating loads acting on this bushing will damage it and hence the cable will come loose.

Make sure that you lay the cables with sufficiently large bend radii.

Avoid vibration on the cables.

Protect the cables from strain.

Protect the sensor from vapors and liquids.

The output signal of the 8524 is, with a supply voltage of 10 V, at maximum 15 mV. Hence for a measurement accuracy of 1.5 % you will need a resolution of approx. 10 μ V or better. Hence interference will be picked up by the sensor, cables and measurement electronics.

The following points apply to the sensor's electrical connection:

- Locate the sensor, the cable and the measuring instrument outside the fields of high-energy equipment.

This includes transformers, motors, contactors, frequency converters and so forth. Otherwise the electromagnetic fields from such equipment will act with their full effect on the measuring chain, causing incorrect measurements.

- Lay the measuring lines separately from high-power cables.

If the measuring lines are laid parallel to such cables, interference will be coupled in inductively and capacitatively.

In some cases it will be helpful to place an extra shield as additional protection over the measuring cable, or to lay it in a metal tube or pipe.

5. Measuring chain adjustment

The sensors of the model 8524 are calibrated ex works. Because of this, every sensor has an individual test and calibration report.

However, you basically have to align every following electronic to the particular sensor. After this adjustment you have done a basic adjustment of the measuring chain.

5.1 Adjustment using the data of the test and calibration report

Depending on the type of the following electronic, you are able to insert the data of test and calibration report directly or you have to use strain gauge simulator or a shunt resistor. With the help of this strain gauge simulator or a shunt resistor you are able to pretend the electric values to the electronic.

5.2 Adjustment using calibration offset (shunt calibration)

Function

During shunt adjustment, a precision resistor (the calibration shunt) is connected between the negative pin of the signal input and the negative pin of the reference supply voltage. The imbalance thus created in the bridge circuit corresponds to a specific change in length, i.e. to a particular load applied to the load cell. An offset, defined in this way, appears at the same time in the output signal, and can be used to adjust the entire measurement chain. The magnitude of the change in the output signal, and the value of the associated calibration shunt, can be found in the sensor's test certificate.

5.3 Adjustment with a physical magnitude

Function

The sensor is subjected to a known physical magnitude. In this way, the calibration is carried out over the entire measuring chain, consisting of the sensor and display device or amplifier.

Adjustment

- Remove any load from the sensor.
- Adjust the zero.
- Load the sensor with a known reference weight.
- Adjust the reference scale value.

If desired, we can prepare factory calibration or recalibration certificates for the sensor or for the entire measuring chain.

These measurements are carried out at the factory on measurement installations.

5.4 Adjustment using a strain gauge simulator

Function

A strain gauge simulator is a bridge simulation circuit, built from precision resistors, which can be put into various output states. The strain gauge simulator (e.g. the burster strain gauge simulator model 9405) is connected to the instrumentation amplifier instead of the sensor.

5.5 Adjustment using a precision voltage source

Note:

The supply voltage of full-bridge strain gauge sensors affects the result of the measurement. It is possible that the actual supply voltage will vary slightly from the rated supply voltage. If you want to verify the proper function of the instrumentation amplifier using a voltage source, you must measure the sensor supply voltage with a precision digital voltmeter, and then calculate the calibration voltage.

Function

The sensor is simulated by a precision voltage source (e.g. the burster DIGISTANT[®] model 4411 or 4423), which you connect to the instrumentation amplifier.

6. Note

Exclusion of warranty liability for operating manuals

All information in the present documentation was prepared and compiled with great care and reproduced subject to effective control measures. No warranty is provided for freedom from errors. We reserve the right to make technical changes. The present information as well as the corresponding technical data can change without notice. Reproduction of any part of this documentation or its processing or revision using electronic systems is prohibited without the manufacturer's prior written approval.

Components, devices and measured value sensors made by burster praezisionsmesstechnik (hereinafter referred to as "product") are the results of targeted development and meticulous research. As of the date of delivery, burster provides a warranty for the proper condition and functioning of these products covering material and production defects for the period specified in the warranty document accompanying the product. However, burster excludes guarantee or warranty obligations as well as any liability beyond that for consequential damages caused by improper use of the product, in particular the implied warranty of success in the market as well as the suitability of the product for a particular purpose. Furthermore, burster assumes no liability for direct, indirect or incidental damages as well as consequential or other damages arising from the provision and use of the present documentation.

Technical Product Information
Commissioning, Function, Fitting Specifications
Model 8524

Technical inquiries:
(+49) 07224 / 645 -0



601-008524EN-5170-051515